

PUMP MOTORS POOL AND SPA



Installation, Care and Maintenance Manual

Table of Contents

Pump Motor Types.....	3
Design Features.....	6
Nameplate Information.....	10
Installation.....	11
Wire Selection Guide.....	13
Installation (Wiring Diagrams).....	13
Troubleshooting Information.....	16
Stock Motor Designs.....	19
Pool Warranty.....	27
Date Codes.....	27

The ABCs of Replacement Motor Selection

- A. Select the frame type you need
- Thru-bolt
 - Round Flanged Keyed
 - Round Flanged Threaded
 - Square Flange
- B. Select the total horsepower output
The total Hp times the service factor of the replacement motor must be equal too or greater than that of the original motor.
- C. Original motor was
- Single-phase or
 - Three-phase
- Must be the same as original motor unless the power supply is being changed.
- D. What was the voltage of the original motor
- Single-phase or
 - Three-phase
- Voltage must match original motor.
- E. What was the original motor's hertz rating?
As a rule 50 Hz and 60 Hz are not interchangeable.

Pump Motor Types

Two Compartment Motors – Square Flange & C-Face

- 1/2 to 3 HP single speed
- 1/2 to 2 HP two speed
- Single phase
- Copper windings
- 303 stainless steel shaft extension
- Locked ball bearings
- NEMA 56C & 56J C-face and 56Y mounting configurations
- Standard and high efficiency
- UL standard “1081” approved

PSC Switchless Motors

- 1/2 to 5 HP single speed and two speed
- Single phase
- Copper windings
- 303 stainless steel shaft extension
- Locked ball bearings
- NEMA 56C, 56J and square flange mounting brackets
- UL standard “1081” approved

Three Phase Pool

- 1/2 to 3 HP single speed
- Three phase
- Copper windings
- 303 stainless steel shaft extension
- Locked ball bearings
- NEMA 56C, 56J and square flange mounting brackets
- UL standard “1081” approved

Spa Motors

- 1/2 to 5 HP single speed and two speed
- Single phase
- Copper windings
- UL standard “1563” approved

Above Ground Pool and Jetted Tub

- 1/2 to 3 HP single speed
- Single phase
- Single and two compartment construction
- Copper windings
- UL “1081” and “1795” approved

Pump Motor Types

56J Two Compartment C-Face



56Z Two Compartment Square Flange



56J Switchless C-Face



56Y Switchless Square Flange



56CZ Pool Cleaner



56Y 3 Phase



ECM Spa



56HC TUV 50 Hz



56Y Above Ground Pool



56Z Circulation Pump



2-Compartment Pool Design Features

1. Easier access. You can get to the serviceable parts almost as easy as turning this page. Loosen just one slotted/hex head captive screw, and the start switch, capacitor, shaft, voltage change device and terminal connections are at your fingertips.

2. Noryl® cover. Corrosion-resistant, nonconductive, the Noryl safety cover provides superior sealing against the elements and impressive strength against impact. It's electrically isolated and has a molded-in capsule to capture the single retaining screw.

3. High-performance start switch. Operates without failure through over a million starts, the switch features an internal centrifugal mechanism for protection and foolproof operation. The switch is made of Valox for strength and moisture resistance and set in a molded-in cavity for protection from contamination. It never needs adjustment. One switch fits all single speed designs and one switch fits all two speed designs, which helps reduce your inventory.

4. Base plate with voltage change selector. Noryl construction means the board resists moisture while it insulates. One-piece terminals provide a continuous electrical path from the internal connections to your side of the board. And changing the voltage is as easy as moving the voltage change device to the desired position, so you'll never have another misconnection.

5. Under the cover. The double-flatted shaft with screwdriver slot lets you use a standard open-ended 1/2 inch wrench or screwdriver for impeller assembly/disassembly. All motors are thermally protected against high ambient temperature and overload conditions. Access to the electrical components is provided by a threaded hole, and one size of start capacitor fits the entire line.

6. Precision-machined shaft. Computer aided shaft machining assures precise dimensions. High grade 303 stainless steel is standard throughout the line.

7. Reliable ball-bearing system. Double sealed to protect against contamination and factory lubricated for life, the bearing system delivers years of trouble-free duty. Locked bearing construction on the drive end absorbs pump thrust and limits endplay to allow very tight impeller clearances.

8. Grease barrier. Provided in the pulley-end bearing to lock out moisture and other contaminants.

9. Proven moisture resistance. The class B insulation system has worked trouble-free for years in the highest moisture applications.

10. Rust protected finish. The steel shell is powder painted and the copper windings are dip-coated with a polyester varnish for outstanding corrosion protection inside and out. A red lacquer finish formulated for high moisture applications protects the rotor.

11. UL and CSA approved. These motors carry component recognition from both Underwriters Laboratories and the Canadian Standards Association. And they've been designed to meet UL standards for pool and spa pumps (UL1081).

Spa, Tub and Above Ground Pool Design Features

1. Precision machined shaft. Computer-aided shaft machining assures precise dimensions.

2. Reliable bearing system. The 56 Frame motor feature a ball bearing system. Ball bearing construction on the drive end absorbs pump thrust and limits endplay to permit tight impeller clearances.

Bearings are double sealed to protect against dirt and moisture and are factory lubricated for long life.

3. Performance engineered terminal board.

Made of tough Valox, the terminal board resists moisture while it insulates. With its structural ribbing, the board is also four times as strong as conventional boards. And engineered mounting tabs ensure a solid, perfectly positioned fit in the motor. Voltage selection is made fast and convenient by interchange of two quick-connect leads or by the voltage change device in the 2 compartment design.

4. Performance engineered switch. The switch construction provides superior contact breaking action for optimum performance. Marathon Electric provides a molded switch cover which insures no moisture related switch problems and protects contacts from contaminants. The direct alignment of the switch contacts with the center-acting centrifugal mechanism provides optimum life without adjustment – ever.

5. Rust protected finish. The steel shell is powder painted and the copper windings are dip-coated with a polyester varnish for outstanding corrosion protection inside and out. A red lacquer finish formulated for high moisture applications protects the rotor from rust.

6. Proven moisture resistance. The class B insulation system provides trouble-free performance. Years of success in the pool and spa market prove our system works, even in the highest moisture applications.

7. Under the OPE endshield. The slotted shaft lets you use a screwdriver for locking the rotor. All motors are thermally protected for high ambient temperature and overload conditions. Access to the electrical components is provided by a line entrance 1/2 – 14 NPSM-2B threaded hole.

8. UL and CSA approved. These motors carry component recognition from both Underwriters Laboratories and the Canadian Standards Association. And they've been designed to meet UL standards for pool and spa pumps (UL1081 and UL1795).

9. Optional air switch. The 56 Frame design makes it possible to lower inventory costs for jetted tub applications that may or may not require an air switch. Pump manufacturers need only stock one motor since our air switch design is available in kit form and can be added after the pump is assembled.

Installation

1. Heat: Nothing destroys a motor faster than heat. It damages the windings, the insulation, the bearing lubricant and the start capacitor. Overheating is caused by the lack of clean, continually circulating air, so ventilation should be the first consideration when installing the motor.

Choose a place free of dirt, dust or airborne debris like leaves. Indoors is best if possible, but not in areas with high humidity (like a laundry room or shower area). If the motor is installed outdoors, choose a shady spot, but make sure it's protected from leaves and grass clippings. If you use a cover for protection from debris or water, make sure there's enough space between the cover and the motor for good ventilation.

Pool and spa motors are equipped with a thermal overload protector that will shut down the motor if it gets too hot, and automatically restart once the windings have cooled. If the motor shuts down often, look for blocked ventilation or overload conditions. If no problem is found or the shutdown continues after the problem has been fixed, call the OEM for a recommendation on matching motor horsepower to the pump.

2. Moisture: Pool and spa motors have superior moisture resistance, but avoid locating the motor where it can be splashed or in low spots where water may collect and flood the motor. Placement at least two inches above ground level is recommended. Motor failure due to flooding is not covered by the warranty.

3. Power Source: Before turning the motor on, confirm that the line voltage, phase and frequency match the specs on the nameplate. Start the motor and check the line voltage at the terminal, checking to make sure that it is within 10% either way. If it's too high, call the local utility. If it's too low, check for overloads, bad connections or wire of the wrong gauge. (See Wire Selection Guide.)

4. Altitude: In high altitudes, motors run hotter. As a rule of thumb, use the next larger horsepower rating than you would normally specify at altitudes above 3300 feet.

5. Mounting: Fasten the motor with the pump assembly securely to a solid base, to avoid problems caused by vibration (like loosening or rotor misalignment). Make sure everything rotates freely before starting the motor.

6. Electrical Connection: Wiring your motor is a simple operation: the wiring diagrams are on the following pages. Refer to the part numbers in the illustration to order a complete wiring diagram or connection label stickers. Make sure the connections are tight to prevent failure or overheating.

7. Grounding: Serious electric shock is possible without proper grounding. **Be sure** to connect the green grounding screw to a grounding conductor, and follow national and local electrical codes.

8. Wire Size: Incorrect voltage at the motor terminals is often the cause of overheating. Make sure the electrical supply wires are sufficient to handle the motor load. The wire sizes shown in the chart on page 13 are general recommendations: always follow local and national electrical codes.

Wire Selection Guide*

Maximum distance from fuse box to motor				
Motor Hp	50 ft.	100 ft.	150 ft.	200 ft.
115V power line				
1/3	14	14	12	12
1/2	14	12	10	10
3/4	12	12	10	8
1	12	10	8	8
1.5	10	10	8	6
2	10	8	6	6
3	—	—	—	—
230V power line				
1/3	14	14	14	14
1/2	14	14	14	14
3/4	14	14	14	14
1	14	14	14	12
1.5	14	14	12	12
2	14	14	12	10
3	12	12	10	10

*Guide for copper conductors only.

THE SIZES SHOWN IN THE ABOVE WIRE SELECTION CHART ARE RECOMMENDATIONS ONLY. ALWAYS FOLLOW LOCAL AND NATIONAL ELECTRICAL CODES.

2 Compartment Design

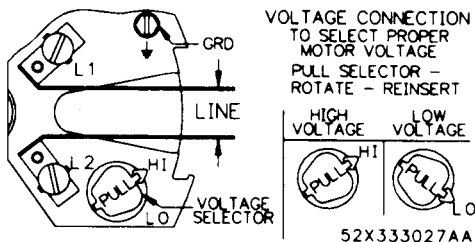

56 FR, 115/230V, single speed, non-reversible

- 1/2 – 1.5 Hp, C-face, keyed and threaded shaft
- 1/2 – 1.5 Hp, square flange
- 1/2 – 1.0 Hp, square flange/full rated

2 Compartment Design

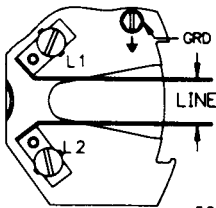

52X333028AA

56 FR, 230V, single speed, non-reversible

- 2 – 2.5 Hp, C-face, keyed and threaded shaft
- 2 – 2.5 Hp, square flange
- 1.5 – 2 Hp, square flange/full rated

2 Compartment Design

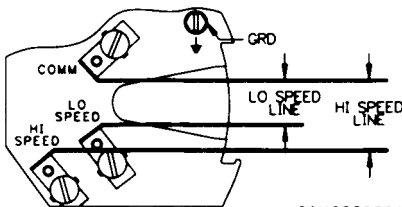

52X333029AA

56 FR, single voltage, two speed, non-reversible

- 1/2 – 1.5 Hp, C-face, keyed and threaded shaft
- 3/4 – 2.0 Hp, square flange

Spa, Jetted Tub, Above Ground Pool Design

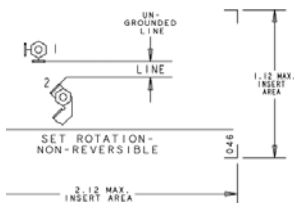

56Y FR, single voltage, single speed, non-reversible

- 1/2 – 1.0 Hp, threaded shaft

Spa, Jetted Tub, Above Ground Pool Design

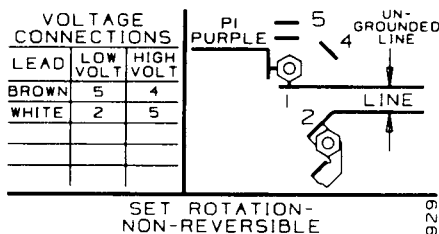

56Y FR, 115/230V, single speed, non-reversible

- 1.5 Hp, threaded shaft

Spa, Jetted Tub, Above Ground Pool Design

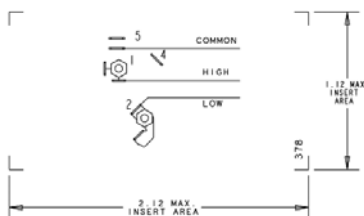

56Y FR, single speed, two speed, non-reversible

- 1/2 – 1.5 Hp, threaded shaft

PSC Switchless Design

TO CHANGE VOLTAGE:

1. POWER MUST **NOT** BE CONNECTED.
2. **PULL** SELECTOR PLUG OUT APPROXIMATELY 1/4".
3. **ROTATE** PLUG TO ALIGN ARROW TO 115V OR 230V AS DESIRED.
4. **PUSH** PLUG BACK IN APPROXIMATELY 1/4".

52X333179AA

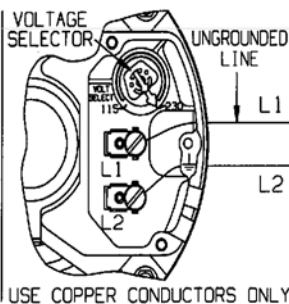

Motor Troubleshooting

⚠️ WARNING Turn off power at the electrical service entrance fuse or breaker box before touching motor or removing cover.

Motor won't start. No hum, no sound.

No power.

Check fuse or circuit breaker.

No power to motor.

Check power connection. Check for loose connections. Apply power, check voltage at motor terminals with voltmeter. **⚠️ CAUTION** Turn power off again at the electrical service entrance fuse or breaker box before proceeding. Check motor overload continuity. See winding problem below.

Motor won't start. Hums.

Locked bearings.

Uncouple pump and spin motor shaft. Check for tight pump seal, obstruction in pump housing or bad bearing.

Incorrect connections.

Check motor connection diagram. Check control circuit diagram.

Low voltage

Motor terminal voltage must be within + or - 10% of nameplate voltage.

Excessive load.

Clogged pump impeller. Bent shaft or bad bearing.

Winding problem.

Check for short, open or ground in winding, lead connections or winding to motor housing.

Start switch open.

Switch should be closed at standstill. Check continuity across contacts.

Start capacitor failure.

White residue probably means faulty capacitor.

Loose capacitor connections.

Visual inspection.

Note: “Capacitor Trouble Shooting Procedure” on page 21.

Excessive noise, vibration.**Defective motor bearings.**

Spin unloaded shaft, check noise.

Loose or binding parts.

Visual inspection of pump and motor.

Bent shaft.

Remove motor and check shaft run-out.

Start switch doesn't open.

Start/stop, start/stop, if motor noise disappears, switch may be defective.

Motor hot, smoking or cycling.**Motor overloaded.**

Full-load current greater than nameplate can mean excessive pump load.

Clogged air openings.

Visual/manual inspection.

Voltage too high/low.

Must be within + or – 10%.

Incorrect connection.

Check nameplate and control diagrams.

Winding shorted or grounded.

Check winding for damage. Check for ground condition. Measure winding resistance.

Start switch fails to open.

Check for welded contacts. Check for broken mech spring. Replace switch.

Run capacitor failure.

Bulged capacitor indicates failure.

Hot or noisy bearings.

Endshields loose or cocked.

Check through-bolts for tightness. Check frame-to-endshield rabbet fit. Spin motor shaft, should turn freely.

Bent shaft.

Measure shaft run-out (straightness).

Defective bearing.

Spin shaft, check for noise, endplay.

Capacitor Troubleshooting

1. To check capacitor ohmmeter, remove all power from the motor.
2. Use insulated screwdriver to discharge capacitor by shorting across terminals.
3. Set ohmmeter to highest value, put clips on capacitor terminals.
4. Check for the following indications:
 - a. Needle drops to zero range and slowly rises, capacitor probably good.
 - b. Needle drops and stays at zero, capacitor probably shorted.
 - c. Needle remains at high value, capacitor probably has open circuit.

Stock Swimming Pool Motors

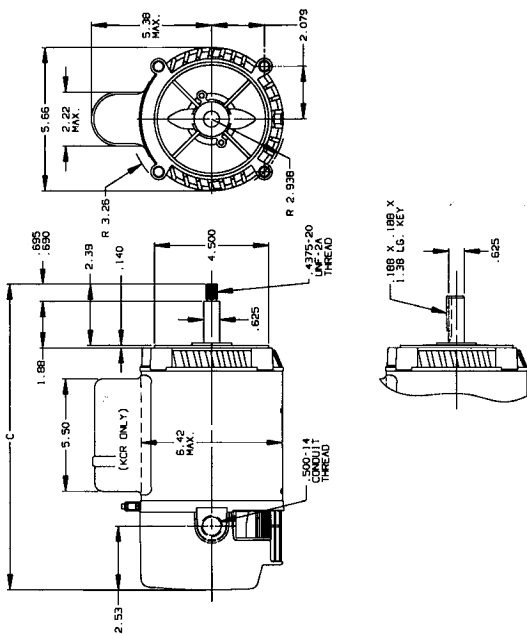

Stock Swimming Pool Motors

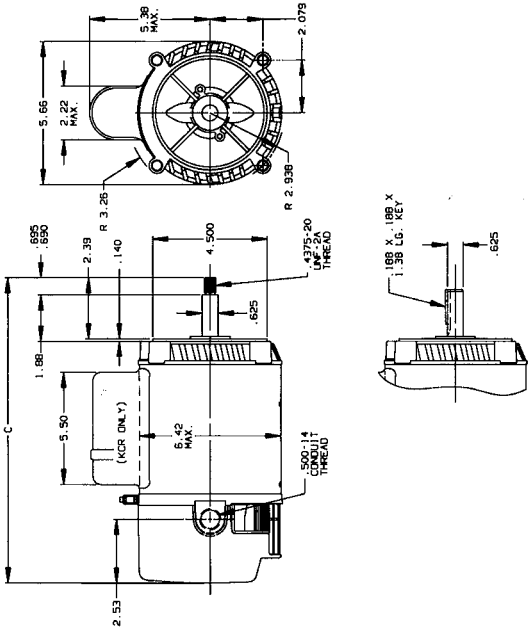

Stock Swimming Pool Motors

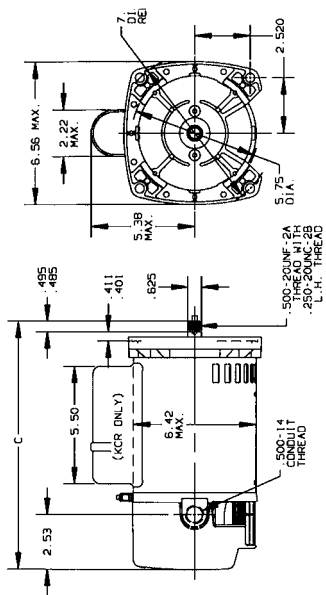

Stock Swimming Pool Motors

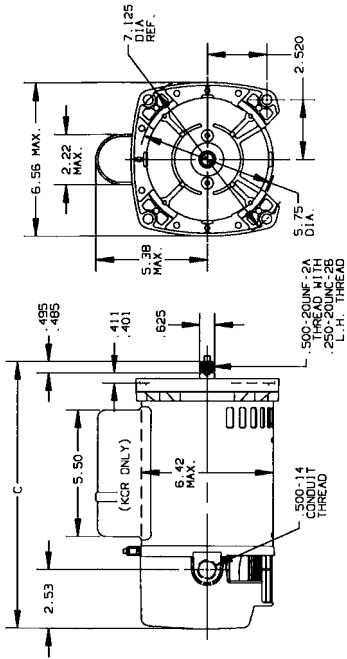

Stock Spa/Jetted Tub/Above Ground Pool Pump Motors

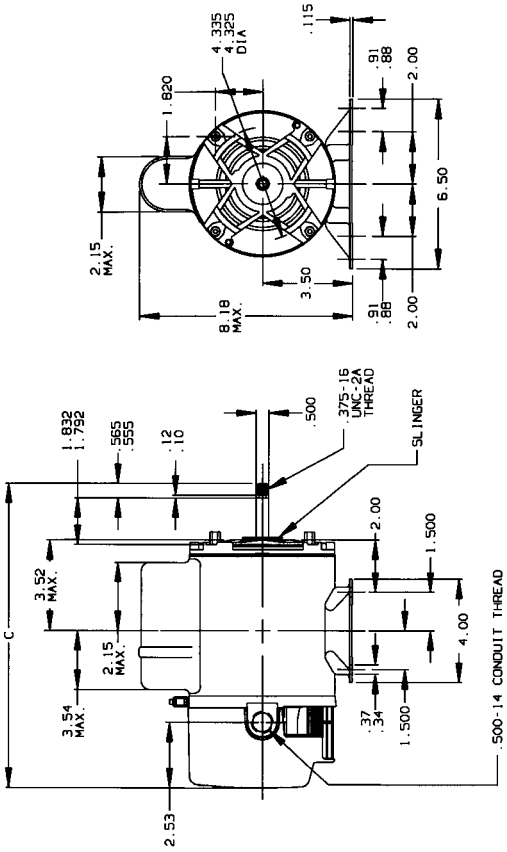

Stock Spa/Jetted Tub/Above Ground Pool Pump Motors

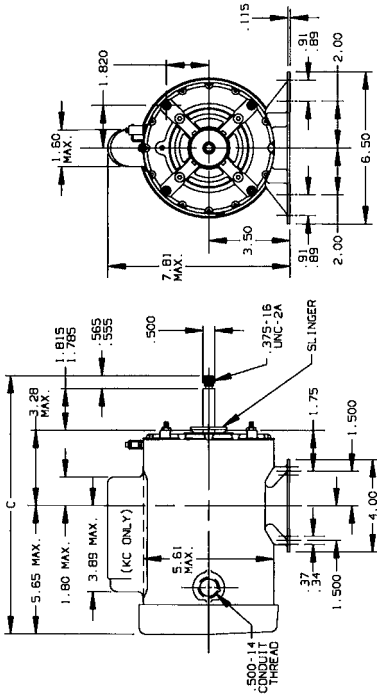

Stock Single Speed Switchless Pump Motors

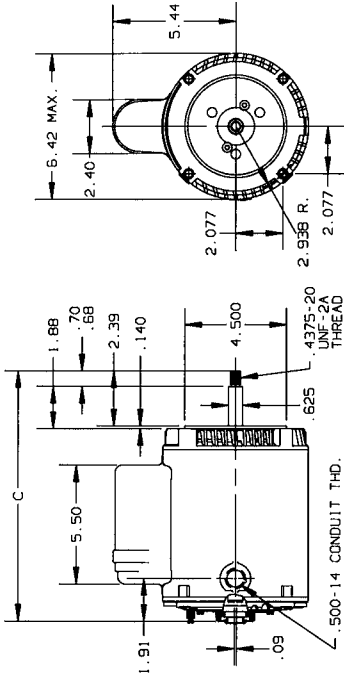

Stock Single Speed Switchless Pump Motors

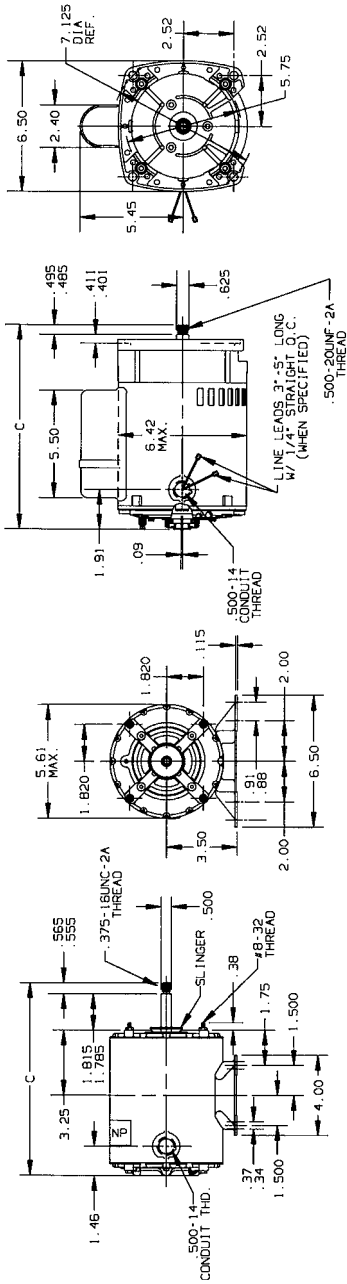

New Date Codes (Effective Jan. 1, 2007)

1. The first character represents the month of manufacture:

A - January	G - July
B - February	H - August
C - March	I - September
D - April	J - October
E - May	K - November
F - June	L - December

Date Codes (First and Second Letters)

Year	Jan.	Feb.	Mar.	Apr.	May	Jun.	Jul.	Aug.	Sept.	Oct.	Nov.	Dec.
1990	NE	OE	PE	RE	SE	TE	UE	VE	WE	XE	YE	ZE
1991	NF	OF	PF	RF	SF	TF	UF	VF	WF	XF	YF	ZF
1992	NG	OG	PG	RG	SG	TG	UG	VG	WG	XG	YG	ZG
1993	NH	OH	PH	RH	SH	TH	UH	VH	WH	XH	YH	ZH
1994	NJ	OJ	PJ	RJ	SJ	TJ	UJ	VJ	WJ	XJ	YJ	ZJ
1995	NK	OK	PK	RK	SK	TK	UK	VK	WK	XK	YK	ZK
1996	NL	OL	PL	RL	SL	TL	UL	VL	WL	XL	YL	ZL
1997	NM	OM	PM	RM	SM	TM	UM	VM	WM	XM	YM	ZM
1998	NN	ON	PN	RN	SN	TN	UN	VN	WN	XN	YN	ZN
1999	NP	OP	PP	RP	SP	TP	UP	VP	WP	XP	YP	ZP
2000	NR	OR	PR	RR	SR	TR	UR	VR	WR	XR	YR	ZR
2001	NS	OS	PS	RS	SS	TS	US	VS	WS	XS	YS	ZS
2002	NT	OT	PT	RT	ST	TT	UT	VT	WT	XT	YT	ZT
2003	NV	OV	PV	RV	SV	TV	UV	VV	WV	XV	YV	ZV
2004	NW	OW	PW	RW	SW	TW	UW	VW	WW	XW	YW	ZW
2005	NX	OX	PX	RX	SX	TX	UX	VX	WX	XX	YX	ZX
2006	NY	OY	PY	RY	SY	TY	UY	VY	WY	XY	YY	ZY

2007 A07* B07* C07* D07* E07* F07* G07* H07* I07* J07* K07* L07* 2008 A08* B08*
 C08* D08* E08* F08* G08* H08* I08* J08* K08* L08*

*There will be a fourth digit that represents the manufacturing plant.

www.pumpmotors.com



GEK-100900D
Wausau, WI 54402

6326M-SK-500-10/08-TG

